





# 20L Microwave Oven

**Model Number P70H20EL-DG-BLU**

**INSTRUCTION MANUAL**

**AFTER SALES SUPPORT**

  1300 886 649

 [info@tempo.org](mailto:info@tempo.org)

MODEL: P70H20EL-DG-BLU PRODUCT CODE: 56354 03/2017



N13275

# Welcome

Congratulations on choosing to buy a STIRLING® product.

All products brought to you by STIRLING® are manufactured to the highest standards of performance and safety and, as part of our philosophy of customer service and satisfaction, are backed by our comprehensive 3 Year Warranty.

We hope you will enjoy using your purchase for many years to come.

# Contents

|           |   |
|-----------|---|
| <b>02</b> | <b>Welcome</b>                                      |
| <b>04</b> | <b>Warranty Details</b>                             |
| <b>05</b> | <b>General Safety Instructions</b>                  |
| <b>08</b> | <b>Product Overview</b>                             |
| <b>11</b> | <b>Getting Started</b>                              |
| <b>16</b> | <b>Instructions</b>                                 |
| <b>21</b> | <b>Cleaning and Care</b>                            |
| <b>22</b> | <b>FAQs and Troubleshooting Guide</b>               |
| <b>24</b> | <b>Other Useful Information</b>                     |
| <b>26</b> | <b>Recipes</b>                                      |
| <b>31</b> | <b>Repair and Refurbished Goods or Parts Notice</b> |



20L Microwave Oven

# Warranty Details

REGISTER YOUR PURCHASE AT [www.aldi.com.au/en/about-aldi/product-registration/](http://www.aldi.com.au/en/about-aldi/product-registration/) TO KEEP UP-TO-DATE WITH IMPORTANT PRODUCT INFORMATION

The product is guaranteed to be free from defects in workmanship and parts for a period of 36 months from the date of purchase. Defects that occur within this warranty period, under normal use and care, will be repaired, replaced or refunded at our discretion, solely at our option with no charge for parts and labour. The benefits conferred by this warranty are in addition to all rights and remedies in respect of the product that the consumer has under the Competition and Consumer Act 2010 and similar state and territory laws.

Our goods come with guarantees that cannot be excluded under the Australian Consumer Law. You are entitled to a replacement or refund for a major failure and to compensation for any other reasonably foreseeable loss or damage. You are also entitled to have the goods repaired or replaced if the goods fail to be of acceptable quality and the failure does not amount to a major failure.



# General Safety Instructions

## IMPORTANT SAFETY INSTRUCTIONS READ CAREFULLY AND KEEP FOR FUTURE REFERENCE

**Read this manual thoroughly before first use.** The safety precautions enclosed herein reduce the risk of fire, electric shock and injury when correctly adhered to. **Keep the manual in a safe place for future reference**, along with the completed warranty card, purchase receipt and carton. Note the product serial number on this manual, so you always have it ready at hand. If applicable, pass these instructions on to the next owner of the appliance.

**Always follow basic safety precautions and accident prevention measures when using an electrical appliance, including the following:**

### Precautions to avoid possible exposure to excessive microwave energy

- Do not tamper with the safety locking mechanism, and do not attempt to use the microwave oven with the door open. The door needs to be tightly shut to prevent harmful exposure to microwave energy.
- Do not allow any object to prevent the door from closing. Also, do not allow cleaner residue to accumulate on sealing surfaces.
- Do not use the oven if it is damaged. It is particularly important that there is no damage to the oven door (bent, warped or otherwise damaged), hinges and latches (broken or loosened), door seals and sealing surfaces.
- **WARNING!** If the door or door seals are damaged, the oven must not be operated until it has been repaired by a competent person.
- **WARNING!** Do not attempt to repair the oven or adjust it yourself. Any repair must only be carried out by qualified personnel. It is hazardous for anyone else to remove a cover which protects against exposure to microwave energy.

### Precautions to avoid the risk of fire in the microwave interior

- Keep an eye on the microwave oven when heating food in plastic or paper containers as these could ignite.
- If you detect smoke, switch the oven off immediately, unplug it, and keep the oven door closed in order to stifle any flames.
- **WARNING!** Do not heat oil or fat for deep frying as its temperature cannot be controlled.
- Remove wire twist ties from paper or plastic bags before placing them in the oven.
- Do not overcook food.
- Do not leave paper products, cooking utensils, or food in the interior, and do not use the oven for storage purposes when it is not in use.
- After use wipe the waveguide cover first with a damp, then a dry cloth, to remove any food splashes and grease. Built-up grease may overheat and begin to cause smoke or catch fire.
- The appliance is not intended to be operated by means of an external timer or separate remote control system.

# General Safety Instructions (Cont.)

## Electrical safety and cord handling

- **Voltage:** Make sure that your outlet voltage and circuit frequency correspond to the voltage stated on the appliance rating plate.
- **Power outlet:** Connect the appliance to a properly earthed power outlet, which must be readily accessible so that you can easily unplug it if necessary.
- **Power cord:** Do not kink or damage the power cord. Do not let it hang over the edge of a table or benchtop, and do not let it touch hot or sharp surfaces. Make sure the cord does not run under the microwave oven. Run it so that there will be no risk of anyone pulling it inadvertently or tripping over it.
- **Electrical safety:** Do not insert any objects into the appliance.
- **WARNING!** To reduce the risk of electrocution and other electrical hazards, do not immerse the cord or plug in water, do not spill liquids into the oven, and do not operate it with wet hands.
- **WARNING!** Do not operate this appliance if it has a damaged cord or plug, if it is not working properly, or if it has been damaged or dropped, or if its door seal is damaged. In such a case, contact our after sales support centre.
- **WARNING!** If the appliance and/or its supply cord or plug are damaged, it must be replaced by the manufacturer, its service agent or a similarly qualified person in order to avoid a hazard. Do not attempt to repair, disassemble, or modify the appliance. There are no user-serviceable parts contained within.
- **Disconnection:** Switch the appliance off and unplug it from the power supply after use and before cleaning, servicing, maintenance, or moving the appliance. Do not pull the cord when disconnecting, grip the plug and pull it gently out of the outlet.
- **Safety switch:** The installation of a residual current device (safety switch) is recommended to provide additional safety protection when using electrical appliances. It is advisable that a safety switch with a rated residual operating current not exceeding 30mA be installed in the electrical circuit supplying the appliance. See your electrician for professional advice.

## Usage conditions and restrictions

- **Domestic use only:** This appliance is intended for indoor household use only. It is not suitable for commercial, industrial, trade or laboratory use.
- **Intended use:** This microwave oven is specifically designed for heating, cooking or defrosting food or beverages in a domestic environment. Do not use it for anything other than its intended purpose. Drying of food or clothing and heating of warming pads, slippers, sponges, damp cloths and similar items may lead to risk of injury, ignition or fire.

# General Safety Instructions (Cont.)

- **Do not use when empty:** Do not operate the microwave oven without any liquid or food inside the oven. This would damage the oven.
- **No outdoor use:** Do not use the appliance outdoors.
- **Usage restrictions:** The appliance is not intended for use by persons (including children) with reduced physical, sensory or mental capabilities, or lack of experience and knowledge, unless they have been given supervision or instruction concerning use of the appliance by a person responsible for their safety.
- **Children:** Supervise children to ensure they do not play with the appliance. Only allow children to use the oven without supervision when adequate instructions have been given so that the child is able to use the oven in a safe way and understands the hazards of improper use. Do not allow children to clean the microwave oven or perform user maintenance.
- **No external timer:** The appliance is not intended to be operated by means of an external timer or separate remote control system.
- **Accessories:** Any accessories not recommended by the manufacturer may cause injuries to persons.
- **Utensils:** Only use utensils that are suitable for use in a microwave oven.
- **Cleaning:** Maintain the oven in a clean condition to avoid surface deterioration, which could affect its working life and result in a hazard risk. Clean the oven regularly and remove food residues from door seals, cavities and adjacent parts. Do not use a steam cleaner for cleaning any part of the microwave oven. Do not use corrosive chemicals in this appliance.
- **Improper use:** Improper installation or use of accessories not recommended in this manual may result in fire, electric shock and/or personal injury. We accept no liability for any eventual damages due to improper use, incorrect handling or noncompliance with these instructions.

## CAUTION: HOT!

- **Hot cookware:** After cooking, the container is very hot. Use oven mitts to avoid burns when handling cooking utensils that have become hot because of the heat transferred from the food.
- **Hot surfaces:** Take due care, accessible surfaces may be hot during operation.
- **Hot steam:** To avoid burns from hot steam, always open any lids away from your face and body. Take the same precautions when removing microwave plastic wrap or opening popcorn or microwave oven cooking bags.
- **Hot drinks:** Microwave heating of beverages can result in delayed eruptive boiling, therefore take utmost care when handling a container with hot drinks.
- **Hot food:** Always check the temperature before serving.
- **Baby food:** To avoid burns, always stir or shake the contents of feeding bottles and baby food jars.

# Product Overview

## Scope of delivery

### (A) Microwave oven parts and features

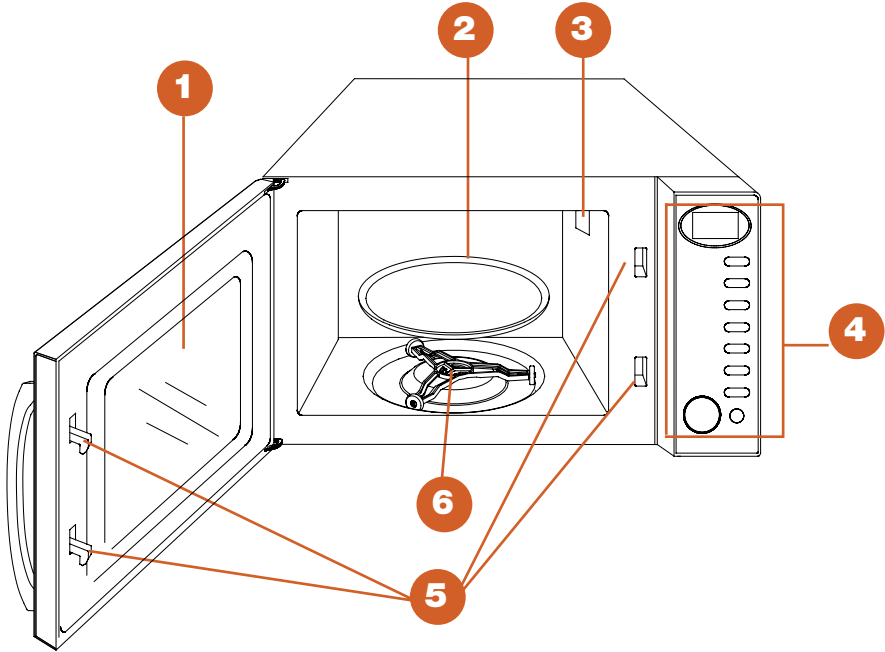

- 1 Viewing window:** allows you to see the cooking status.
- 2 Glass turntable (245mm):** the food sits on the turntable, its rotation during operation helps to cook food evenly.  
**CAUTION!** Place the rotating ring (6) onto the rotating axis in the centre of the cavity base, then place the turntable on top and ensure it can rotate freely.
- 3 Waveguide cover:** this cover is inside the microwave oven, next to the wall of control panel. **Never remove this cover!**
- 4 Control panel:** this panel contains the digital display, time/menu dial and operation buttons (see opposite for details).
- 5 Door safety lock system:** the door of the microwave oven must be properly closed in order for it to operate.
- 6 Rotating ring:** the glass turntable sits on the wheels of the rotating ring; it supports the turntable and helps it to balance when rotating.



# Product Overview (Cont.)

## (B) Control panel

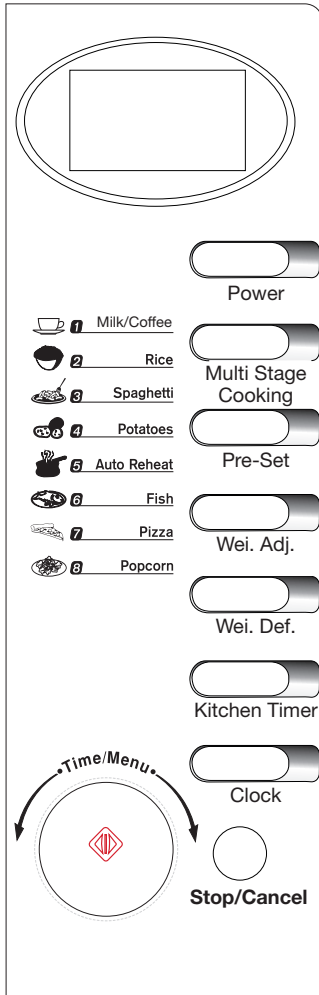

**Digital Display:** Cooking time, power level, weight or servings indicators, and the current time are displayed here (see page 10 for details).

**Auto Cook Settings:** The numbers 1–8 are the codes for cooking popular foods: beverages, rice, spaghetti, potatoes, fish, pizza, popcorn, and auto reheat.

**Power:** Press to set the microwave cooking power level.

**Multi Stage Cooking:** Press to set a multistage cooking program.

**Pre-Set:** Press to set a pre-set (delayed start) timer.

**Wei. Adj.:** Press to set the desired weight/servings for the quick cook settings.

**Wei. Def.:** Press to set the weight of food to be defrosted.

**Kitchen Timer:** Press to set the kitchen timer (up to 95 mins).

**Clock:** Press to set the clock time.

**Time/Menu:** Turn the dial to select an auto cooking function, input a cooking time, select a food weight/serving, or set the clock time.

**Start/Quick Start (  ): Press to start a set program. Press multiple times to set the desired cooking time, without previously setting a power level and a cooking time.**

**Stop/Cancel:** Press to cancel a setting or reset the microwave before setting a cooking program. Press once to temporarily stop cooking, or twice to cancel cooking altogether.

## (C) Documentation (not pictured)

Instruction manual, Quick start guide, Warranty certificate

### NOTE:













Due to continued product improvement, images and illustrations in this manual may vary slightly from the product purchased. All images in this manual are for reference purposes only. Parts are not necessarily pictured to scale.

# Product Overview (Cont.)

## Icons on the digital display

The digital display at the top of the control panel features the following symbols, which illuminate when the respective function is selected.



-  Auto cook settings
-  Zero microwave power
-  Pause
-  Clock
-  Child lock
-  Power level (%)
-  Weight (g)
-  Weight defrost
-  Microwave working
-  Stage 1 of multistage cooking
-  High power level
-  Stage 2 of multistage cooking
-  Low power level

# Getting Started

## Unpacking

- **Unpack:** Remove all packing materials from outside and inside the oven. If there is a safe film over the oven door, tear it off before use. Keep the original packaging carton and materials in a safe place. It will help prevent any damage if the product needs to be transported in the future, and you can use it to store the appliance when it is not in use. In the event that it is to be disposed of, please recycle all packaging materials where possible. Plastic wrapping can be a suffocation hazard for babies and young children, so ensure all packaging materials are out of their reach and disposed of safely.
- **Inspect:** Unwind the power supply cord to its full length and inspect it for damage. Then check the microwave oven for any damage, such as a misaligned or bent door, damaged door seals and sealing surfaces, broken or loose door hinges and latches, dents inside the cavity or on the door.  
**WARNING:** If there is any damage to the appliance or its cord, do not operate the microwave oven! Contact our after sales support centre.
- **Read:** Read this manual to familiarise yourself with the parts and operating principles. Pay particular attention to the safety advice on the previous pages.
- **Clean:** Wipe the inside surfaces of the microwave oven with a damp cloth. Wash the glass turntable with a soft cloth in warm water and a little dish detergent to remove any dust from transport. Rinse and dry thoroughly.

## Installation

- **Position:** Place the microwave oven on a flat, stable surface that can support the weight of the oven plus the heaviest foods likely to be cooked in it.
- **WARNING: Do NOT place the microwave oven:**
  - X In a cabinet; this appliance is intended to be used freestanding, placed against a wall.
  - X Where heat, moisture or high humidity are generated (such as near a gas burner, cooktop or water tank).
  - X Near combustible materials.
  - X Near a TV, radio or antenna; keep a minimum distance of 5m to such appliances in order to avoid potential picture interference.
- **Clearances:** Place the microwave oven with its back against a wall, allowing enough space for ventilation: 20cm of space above the oven, 10cm at the back and 5cm at both sides. Do not cover or block any openings on the appliance. Do not remove the feet.
- **Assembly:** Place the rotating ring in its position in the cavity base and the turntable on top, making sure it sits securely in place and can move freely.  
**WARNING:** Do not operate the appliance without the turntable and rotating ring in their proper positions.

# Getting Started (Cont.)

## Electrical connection

- This appliance must be earthed. We accept no liability for damage to the oven or personal injury resulting from failure to observe any electrical connection procedures. In the event of a malfunction or breakdown, earthing will reduce the risk of an electric shock by providing a path of least resistance for the current.
- The plug must be connected to an appropriate outlet that is installed and earthed in accordance with all local standards and requirements. If unsure, consult an electrician or a service representative. Do not, under any circumstances, cut or remove the third grounding prong from the power plug.
- It is recommended that a separate circuit be provided for use by the microwave oven alone.
- Make sure that the power cord does not run under the oven and that the socket is readily accessible so it can be easily unplugged in an emergency.

## Before first use

The appliance may produce fumes or odour when it is first heating up. This is due to the components being new and can be disregarded safely. We recommend you place a cup of water on the turntable and run the microwave oven on full power for a few times until all odour and/or smoke has dissipated (see page 15 for usage instructions). Ensure there is adequate ventilation.

## Microwave cookware details

Cookware used in a microwave oven must be microwave safe. Suitable materials are listed in the table overleaf.

- **Shape of cooking container:** We recommend round/oval dishes for microwave cooking rather than square/oblong ones, as food in the corners of a container tends to overcook.
- **Heating liquids:** Use a wide-mouthed container for heating liquid, and when it is hot, wait a few moments before opening the container in order to avoid possible hazards caused by delayed eruptive boiling.
- **Placement:** Make sure the cooking container does not touch the interior walls during cooking.
- **Metal:** Microwaves cannot penetrate metal, so **do not use any cookware made of or containing metal**, such as dishes with a metallic trim, metal racks, trays or utensils, aluminium foil, or foil containers.
- **Recycled paper products:** Do not use these when microwave cooking, as they may contain small metal fragments which may cause sparks and/or fires.
- **Browning dish:** When using a browning dish or self-heating container, always place a heat-resistant insulator such as a porcelain plate under it to prevent damage to the turntable and rotating ring.

# Getting Started (Cont.)

## Cookware and utensils guide for microwave cooking

Cookware used in a microwave oven must be microwave safe.

| <input checked="" type="checkbox"/> Recommended     |   |
|---|---|
| Microwave plastic wrap                              | Use to retain steam. Leave a small opening for steam to escape and avoid placing it directly on the food. Do not use when cooking meat. Do not allow it to come into contact with high-fat food as it may melt. |
| Paper towels and paper napkins                      | Use for short-term heating and covering; these absorb excess moisture and prevent spattering. Do not use recycled paper towels, which may contain metal and could ignite.                                       |
| Heat-resistant glass and ceramic dishes             | Use for heating or cooking.   |
| Paper plates and cups                               | Use for short-term heating at low temperatures. Do not use recycled paper, which may contain metal and could ignite.  |
| Wax paper   | Use as a cover to prevent spattering.   |
| Limited Use   |   |
| Aluminium foil                                      | Use narrow strips of foil to prevent overcooking of exposed areas. However, take care not to use too much foil, and keep a distance of 2–3cm between the foil and the cavity wall.                              |
| Ceramic, porcelain and stoneware dishes             | Use these if they are labelled "Microwave Safe". If they are not labelled, test them to make sure they can be used safely. Never use ceramics decorated with a metal rim or glaze.                              |
| Heat-resistant plastic containers                   | Use only if labelled "Microwave Safe", and only according to dish instructions. Avoid when cooking foods with high fat and sugar content. Other plastics can melt.  |
| <input checked="" type="checkbox"/> Not Recommended |   |
| Glass jars and bottles                              | Regular glass is too thin to be used in a microwave. It can shatter and cause damage and injury.  |
| Paper bags  | These are a fire hazard, except for popcorn bags that are designed for microwave use.   |
| Polystyrene plates and cups                         | These can melt and leave an unhealthy residue on food.  |
| Plastic storage and food containers                 | Containers such as margarine tubs can melt in the microwave.  |
| Metal utensils, racks or trays                      | These can damage your oven. Do not use in the microwave.  |

# Getting Started (Cont.)

## Microwave cooking principles

- **Arrange the food.** Arrange the food so the thickest parts are towards the outside of the dish, the thinner parts towards the centre, and spread it evenly. Do not overlap if possible.
- **Cover it.** Cover the food, but not tightly, as some ventilation is necessary for even heating. Covering food will prevent spattering and help food cook evenly.
- **Turn over.** To speed up the cooking time and ensure even cooking, turn pieces of food over, rearrange them or stir the food from the outside to the centre of the dish at least once halfway through cooking.
- **Watch the cooking time.** Cook for the shortest amount of time indicated and add more time as needed. Severely overcooked food can smoke or ignite.
- **Is it done?** Colour and hardness of the food help you to determine if it is done. Indicators include:
  - Steam is coming out from all parts of food, not just the edge.
  - Joints of poultry can be moved easily.
  - Pork or poultry pieces show no signs of blood.
  - Fish is opaque and can be sliced easily with a fork.
- **Let it stand.** After cooking times out, leave the food in the oven for an adequate length of time. This will allow the food to complete its cooking cycle and cool it down in a gradual manner.
- **WARNING! Do not heat liquids and other food in sealed containers** as they are liable to explode. Baby bottles fitted with a screw cap or teat are considered to be sealed containers.
- **No frying.** Do not attempt to fry food in the microwave oven, as hot oil can damage oven parts and utensils, or cause skin burns.
- **No whole eggs.** Do not attempt to boil eggs in their shell, as they may explode, even after microwave heating has ended.
- **Pierce skins.** Pierce food with nonporous skin such as potatoes, whole squash, apples, chestnuts or sausages before cooking.
- **Take special care to prevent the turntable from breaking.**
  - Let the turntable cool down before cleaning.
  - Do not place hot food or utensils on the cold turntable.
  - Do not place frozen food or utensils on the hot turntable.
  - Make sure your cooking container is dry, as a wet surface may generate excessive heat which could damage the glass turntable.

# Getting Started (Cont.)

## First connection

Insert the plug of the microwave oven supply cord into a suitable power point. On first connection, the unit will emit a short beep sound and [ : ] flashes on the display. We recommend that at this stage you set the digital clock to the correct time of day. However, this is not necessary for basic oven use.

## Setting the clock

- The microwave oven clock can be set to a 12 or 24 hour cycle. Press the CLOCK button once for a 12 hour cycle, or twice for a 24 hour cycle. The display will show [ 12H ] or [ 24H ], depending on your selection.
- To set the time of day, turn the TIME/MENU dial to set the correct hour, then press the CLOCK button to confirm. Turn the TIME/MENU dial to set the correct minutes, then press the CLOCK button to confirm. The current time will now be shown on the display.

**NOTE:** To check the clock time during cooking, press the CLOCK button.

## Setting microwave controls

- Each time a button is pressed, a beep will sound to acknowledge the action.
- At the end of a set cooking or defrosting program, [ End ] will be displayed on the screen and the oven will beep 3 times, prompting you to open the door and take out the food. If you do not open the door or press the STOP/CANCEL button, otherwise the oven will repeat beeping every 3 minutes.

## Stopping the oven during operation

- **During operation:** Press the STOP/CANCEL button once to pause the microwave oven, or twice to cancel the program.
- **At initial or input stage:** Press the STOP/CANCEL button once to cancel input programs and resume initial stage.

## Child safety lock

The child safety lock prevents unsupervised operation by young children. Once set, the child lock indicator (a closed lock symbol) will appear on the display screen and the oven cannot be operated.

- **To set the child safety lock,** press and hold the STOP/CANCEL button for about 3 seconds: a beep will sound and the child lock indicator will appear on the display screen. Pressing any button now will be ineffective.
- **To cancel the child safety lock,** press and hold the STOP/CANCEL button for about 3 seconds until the child lock indicator disappears from the display. The microwave oven can now be operated.

# Instructions

## Microwave cooking

Microwave cooking allows you to customise cooking power and time. First, select a power level by pressing the POWER button a number of times (see the table below). Then set the cooking time (maximum 60 minutes), using the TIME/MENU dial, before pressing START/QUICK START.

After the set time has elapsed, the buzzer will beep every 3 minutes and [ End ] will be displayed. Press the STOP/CANCEL button to clear the [ End ] display before starting another cooking function.

### Power levels

| Press Button | Power Level | Cooking Power | Application                |
|--------------|-------------|---------------|----------------------------|
| 1 x          | 100%        | High          | Quick and thorough cooking |
| 2 x          | 80%         | Medium High   | Medium express cooking     |
| 3 x          | 60%         | Medium        | Steaming food              |
| 4 x          | 40%         | Medium Low    | Defrosting food            |
| 5 x          | 20%         | Low           | Keeping warm               |

**Example:** To cook food for 3 minutes with medium microwave (60%) power:

- Place food into the microwave oven and close the door.
- Press the POWER button three times to set the power level to 60%.
- Rotate the TIME/MENU dial until the cooking time [ 3:00 ] is displayed.
- Press START/QUICK START to start cooking. The countdown will start and the remaining cooking time will be displayed.

### Important notes

- Never operate the oven empty.
- The lower the cooking power, the slower the cooking.
- The maximum time that can be set is 60 minutes.
- If you want to turn the food during operation, press the STOP/CANCEL button once to stop operation, turn the food over, and then press START/QUICK START to continue the preset cooking procedure.
- If you intend to remove the food before the preset time, you must press the STOP/CANCEL button twice to clear the preset procedure in order to avoid unintended operation when using the oven next time.



# Instructions (Cont.)

## Quick Start

This is a convenient setting for cooking or heating food quickly at full microwave power.

### Example

- Place the food into the microwave oven and close the door.
- Press START/QUICK START to cook instantly with full power for 30 seconds.
- Press START/QUICK START repeatedly in quick succession to set the cooking time (in 30 second steps, maximum: 12 minutes) and start cooking instantly with full power.

## Multistage cooking

Some recipes may require setting a multistage program involving defrosting and cooking at different power levels. The following example shows the steps involved in setting up such a program.

### Example

- Place the food into the microwave oven and close the door.
- Press the WEI. DEF. button once, then rotate the TIME/MENU dial to choose the food weight for the defrosting stage.
- Press the MULTI STAGE COOKING button.
- Press the POWER button, repeatedly, to select the cooking power, then turn the TIME/MENU dial to select the cooking time for the first cooking stage.
- Press the MULTI STAGE COOKING button again.
- Press the POWER button, repeatedly, to select the cooking power, then turn the TIME/MENU dial to select the cooking time for the second cooking stage.
- Press START/QUICK START to start the multistage program.

### Important notes

- Defrosting can only be set in the first stage.
- Quick start and auto cook functions cannot be set in a multistage program.
- When the first stage is finished, the second stage will start automatically.

# Instructions (Cont.)

## Defrosting food

This feature automatically sets an appropriate defrosting cycle based on the weight of the food (meat, poultry, seafood) to be defrosted. The weight can be set in 100g steps, up to a maximum of 1800g, for automatic defrosting.

### Example

- Place the food to be thawed in the microwave oven and close the door.
- Press the WEI. DEF. button once.
- Rotate the TIME/MENU dial until the food weight is displayed.
- Press START/QUICK START to start defrosting. The countdown will start and the display will show the remaining defrosting time.
- The system will beep during defrosting to prompt you to turn the food over (or to remove parts of the food that are already defrosted). This will ensure even defrosting. Open the door and turn over the food, then close the door and press START/QUICK START again to continue defrosting.
- After the set time has elapsed, the buzzer will beep every 3 minutes and [ End ] will be displayed.
- Press the STOP/CANCEL button to clear the [ End ] display before starting another cooking function.

### Important notes

- It is necessary to turn over the food during operation to obtain a uniform effect.
- Defrosting usually takes longer than cooking food.
- If the food can be cut with a knife, the defrosting process can be considered completed.
- Microwaves penetrates around 4cm into most food.
- Defrosted food should be consumed as soon as possible. Do not refreeze food that has been defrosted.

# Instructions (Cont.)

## Auto cook settings

This microwave oven has several programmed cooking settings for cooking particular types and quantities of food automatically, without the need for setting cooking time or power level.

### Example

- Place the food into the microwave oven and close the door.
- Rotate the TIME/MENU dial to display the codes (see the table below).
- When the desired food code is displayed, press the WEI. ADJ. button (repeatedly) until the desired weight is displayed (the available weight/serving options are listed in the table below).
- Press START/QUICK START to start the program.
- You may need to turn the food over during cooking to ensure even heating.

| Code | Food        | Options | Weight/Serving Options                         |
|------|-------------|---------|--|
| 1    | Milk/Coffee | 3       | 200mL each for beverages                       |
| 2    | Rice        | 4       | 150g - 300g - 450g - 600g                      |
| 3    | Spaghetti * | 3       | 100g - 200g - 300g (* add boiled water)        |
| 4    | Potatoes    | 3       | 230g each                                      |
| 5    | Auto Reheat | 7       | 200g - 300g - 400g - 500g - 600g - 700g - 800g |
| 6    | Fish        | 5       | 200g - 300g - 400g - 500g - 600g               |
| 7    | Pizza       | 3       | 150g - 300g - 450g                             |
| 8    | Popcorn     | 1       | 99g  |

### Important notes

- The programmed auto cooking times are based on the food being at room temperature (20-25°C) before cooking. Food that is colder or warmer may require increased or decreased cooking times.
- Auto cooking results are affected by the shape and size of the food to be cooked, how well it is placed in the microwave, voltage fluctuations and, of course, your personal preference as to how well done you like certain foods cooked. If your food is not cooked to your satisfaction, please adjust the cooking time accordingly.

# Instructions (Cont.)

## Pre-set (delayed start timer)

The pre-set function allows you to program the oven to start cooking at a later time. To use this delayed start timer, the clock must be set to the correct time.

### Example

Suppose it is 11:10 a.m. now and you want the oven to start at 11:30 a.m.

- Place the food into the microwave oven and close the door.
- Set a cooking program, as described on the previous pages, but do not press START/QUICK START.
- Press the PRE-SET button, then rotate the TIME/MENU dial to set the hour digits for your start time [ 11 ].
- Press the PRE-SET button again, then rotate the TIME/MENU dial to set the minute digits for your start time [ 30 ].
- Press START/QUICK START to set the preset program. The pre-set function is now set and the program will start at 11:30 a.m.
- To cancel the pre-set (delayed start timer), press the STOP/CANCEL button.

### WARNING!

- **Fire risk:** For your personal safety, do not program the timer and then leave the microwave oven unattended. Operating an electrical appliance unattended could present a risk of fire or electrical hazards.
- **Health risk:** For food safety reasons, do not leave easily spoiled foods in the oven for too long when using the timer. Some foods should not be left at room temperature in order to prevent the risk of spoilage and bacterial contamination. Consuming spoiled foods can have serious health risks.

## Kitchen timer

The microwave oven has a kitchen timer, or minute minder, which can be set to sound an alarm after a set period of time (max. 95 minutes).

### Example

- During waiting or cooking mode, press the KITCHEN TIMER button once, then rotate the TIME/MENU dial to set the time period and, finally, press START/QUICK START to start the timer countdown. When the countdown time has expired, the oven will beep.
- To check the remaining time during the countdown, press the KITCHEN TIMER button. The time remaining will be displayed for 4 seconds.
- To stop or cancel the timer, press the STOP/CANCEL button.

# Cleaning and Care

**WARNING:** Before cleaning or maintenance, make sure to turn off the microwave oven and disconnect the plug from the wall socket.

- Keep the **inside** of the microwave oven clean. When food splatters or liquids spill or adhere to the microwave oven ceiling and walls, wipe them with a damp cloth and a little mild detergent, if necessary. Do NOT remove the waveguide cover.
- **CAUTION:** Do not use caustic, abrasive or harsh cleaners as they may stain, streak or dull the surfaces.
- **CAUTION:** To prevent damage to the operating parts inside the microwave oven, do not let water seep into the ventilation openings. Clean the outside surfaces with a damp cloth only. Do not immerse the appliance in water or other liquids when cleaning.
- Wipe the **door** and **window**, the **door seals** and adjacent parts with a damp cloth to remove any spills or splatters. Do not use abrasive cleaners or sharp metal scrapers as they can scratch the surface, which may result in shattering of the glass.
- Do not allow the **control panel** to become wet. Clean it with a soft, damp cloth. When cleaning the control panel, leave the microwave oven door open to prevent the microwave oven from turning on.
- If steam accumulates inside or around the outside of the microwave oven **door**, wipe it with a soft cloth. This is normal and may occur when the microwave oven is operated under high humidity conditions.
- It is occasionally necessary to remove the glass **turntable** for cleaning. Wash it in warm, sudsy water, or in a dishwasher.
- To avoid excessive noise, wipe the **rotating ring** and **microwave floor** regularly with a damp cloth. When removing the glass turntable support from the cavity floor for cleaning, be sure to replace it afterwards in the proper position on the rotating axis.
- To remove persistent **odours** from your microwave oven, combine a cup of water with the juice and skin of one lemon in a deep microwavable bowl and microwave for 2-3 minutes. Then wipe the oven thoroughly and dry with a soft cloth. Alternatively, put some orange peel into oven and heat it for 1 minute.
- Should it become necessary to replace the microwave oven **light**, consult a service technician to have it replaced, or contact our after sales support centre.
- **CAUTION:** Make sure to clean your microwave oven regularly and remove any food residues. Failure to maintain the microwave in a clean condition could lead to deterioration of the surface, which could adversely affect the life of the appliance and could present a potential hazard.

# FAQs and Troubleshooting Guide

If you encounter problems with your microwave oven, check in the table below to see whether your problem can be solved easily without a service call.

| Problem  | Possible Cause  | Solution   |
|--|---|--|
| The microwave oven does not work.                            | Incorrect or faulty power connection, or tripped fuse.  | Make sure the oven is plugged in securely. If it is not, remove the plug from the outlet, wait 10 seconds and plug it in again securely.<br>Check for a blown circuit fuse or a tripped main circuit breaker.<br>If these seem to be operating properly, test the outlet with another appliance. |
|  | The oven door is not properly closed.   | Make sure the door is securely closed and the door safety lock system is engaged. Otherwise, the microwave energy will not flow into the oven.   |
|  | The oven is programmed to start at a later time.  | Check to ensure that the control panel is programmed correctly.  |
| My food gets cooked during defrosting.                       | The defrosting time was too long, or the oven was set to operate at a power level that is too high for defrosting.  | Reduce the defrosting time. For best results, use the Defrost setting and enter the weight of the food to be defrosted.  |
| My bread rolls burn during warming in the microwave.         | The warming time was too long.  | Small food items can burn rapidly and only require very brief heating periods. One bread roll will reheat in 5-10 seconds.   |
| Using the microwave oven causes interference to my radio/TV. | Try eliminating or reducing any interference by: <ul style="list-style-type: none"> <li>• Cleaning the microwave oven door and seal.</li> <li>• Re-orienting the antenna of the radio or television.</li> <li>• Relocating the microwave with respect to the receiver.</li> <li>• Moving the microwave oven away from the receiver.</li> <li>• Plugging the microwave oven into a different power outlet so that it and the receiver are on different branch circuits.</li> </ul> |  |

If none of the solutions offered above help you solve the problem, follow the troubleshooting tips on the following page before calling for service.

# FAQs and Troubleshooting Guide (Cont.)

## Troubleshooting tips

If none of the solutions offered on the previous page help you solve the problem, follow the troubleshooting tips below before contacting a qualified technician or our after sales support centre for advice.

Place a small cup of water (approx. 150mL) in a glass measure in the oven and close the door securely. The oven lamp should go off if the door is closed properly. Let the oven work for one minute.

- Does the oven lamp light up?
- Does the cooling fan work? (Put your hand over the rear ventilation openings.)
- Does the turntable rotate? (The turntable can rotate clockwise or anticlockwise. This is quite normal.)
- Is the water in the cup hot?

If the answer to any of the above questions is "no", please check your wall socket and the fuse in your meter box. If both the wall socket and the fuse are functioning properly, contact our after sales support centre using the details at the bottom of the page.

## Radio interference

Operation of the microwave oven can cause interference to your radio, TV or similar equipment. In such a case, try to reduce or eliminate interference by:

- Cleaning the microwave oven door and seal.
- Re-orienting the antenna of the radio or television.
- Moving the microwave oven away from the receiver.
- Plugging the microwave oven into a different power outlet so that it and the receiver are on different branch circuits.

## Microwave radiation

This product is a Group 2 Class B ISM equipment. In Group 2 equipment, radio-frequency energy is intentionally generated and/or used in the form of electromagnetic radiation. Class B equipment is suitable for use in domestic establishments and in establishments directly connected to a low voltage power supply network which supplies buildings used for domestic purposes.

# Other Useful Information

## Moving the appliance

If you need to move the appliance, we recommend you use the original carton for safe transportation. Before moving the oven, remove the turntable and transport it separately, or make sure to secure it to avoid damaging it during transport.

## Storing the appliance

If you are not going to use the appliance for an extended period of time, unplug it and store it in the original carton to protect it from dust. Store the unit in a dry place, out of children's reach.

## Service and repair

- In case of damage or malfunction, have the appliance repaired by a qualified technician, or contact our after sales support centre for advice.
- Do not operate any appliance with a damaged cord or plug, or when it is working abnormally. If the cord is damaged, call the after sales support line.
- If it becomes necessary to replace the microwave light, consult a qualified electrician to have it replaced or contact our after sales support centre for help.
- **DANGER: Do not try to adjust or repair the microwave oven yourself. Do not attempt to take the appliance apart.**

## Spare parts

Our after sales support centre stocks the following spare parts for the STIRLING Vintage Collection 20L Microwave Oven (P70H20EL-DG-BLK, P70H20EL-DG-WHT, P70H20EL-DG-BLU).

Feet

Rotating axis (shaft)

Rotating (roller) ring

Turntable (glass plate)

To purchase a spare part, call the centre on 1300 886 649 or email us at [info@tempo.org](mailto:info@tempo.org)



# Other Useful Information (Cont.)

## Technical specifications

|                        |                             |
|------------------------|-----------------------------|
| Voltage                | 220-240V AC, 50Hz           |
| Rated Input Power      | 1200W (Microwave)           |
| Rated Output Power     | 700W                        |
| Microwave Frequency    | 2450MHz                     |
| Outside Dimensions     | 452 (W) x 262 (H) x 335 (D) |
| Oven Cavity Dimensions | 295 (W) x 180 (H) x 255 (D) |
| Glass Turntable        | 245mm diameter              |
| Oven Capacity          | 20 Litres                   |
| Weight (approx.)       | 10.7kg                      |

This appliance has been fully tested and meets all requirements as set out by standards AS/NZS 60335.1 and AS/NZS 60335.2.25.

## Responsible disposal

At the end of its working life, do not throw this appliance out with your household rubbish. Electrical and electronic products contain substances that can have a detrimental effect on the environment and human health if disposed of inappropriately. Observe any local regulations regarding the disposal of electrical consumer goods and dispose of the appliance appropriately for recycling. Contact your local authorities for advice on recycling facilities in your area.

# Recipes

## Chicken risotto

### Ingredients (serves 4)

400g chicken thigh fillets, diced  
1 small leek, thinly sliced  
150g button mushrooms, sliced  
3/4 cup arborio rice  
450mL chicken stock  
1 tsp dried oregano  
1/2 cup grated Parmesan cheese  
1/2 cup frozen peas  
Freshly ground black pepper  
50g flaked almonds, toasted

### Method

- Combine the diced chicken, leek, mushrooms, rice, stock and oregano in a microwave safe dish. Cover.
- Place the dish on the glass turntable in the microwave oven.
- Cook the dish with 100% microwave power for 10 minutes.
- At the end of the 10 minutes, open the door, lift off the cover and stir the risotto, taking care not to burn yourself on the hot steam that is likely to escape. Replace the cover after stirring.
- Cook for a further 15 minutes with 60% microwave power.
- At the end of the cooking time, stir through the cheese, peas and pepper. Cover and stand for 5 minutes.
- Serve sprinkled with toasted almond flakes.

# Recipes (Cont.)

## Snapper fillets with tarragon

### Ingredients (serves 4)

2 tbsp olive oil

Juice from ½ lemon

¼ tsp salt

¼ tsp freshly ground black pepper

8 large sprigs of fresh tarragon, chopped (or 1½ tsp dried)

500g small snapper fillets

### Method

- Combine the olive oil, lemon juice, salt, pepper and tarragon in a bowl. Turn the fish fillets in the oil mixture on both sides. Arrange the fillets on a microwave safe plate with the thickest portion to the outside, tucking under the thinnest parts of the fillets for even cooking. Let the prepared fish fillets stand for 10 minutes to marinade.
- Cover the fish tightly with plastic wrap and vent by turning back one corner.
- Cook the fish with 60% microwave power for 6 minutes.
- At the end of the cooking time, take the dish carefully out of the oven using oven mitts. The fish should be just opaque and firm to the touch. If it flakes and breaks up, cook it a minute less next time; if it is undercooked, cook it for another minute with 100% microwave power, checking every 20 seconds.

# Recipes (Cont.)

## Vegetable crisps

### Ingredients

1 potato (or sweet potato, or any other root vegetable)

Olive oil (optional)

Sea salt and/or other seasonings of your choice (for example, smoked salt, dried chilli flakes, paprika, dried herbs, vegetable seasoning)

### Method

- Scrub the potato clean, then cut it into very thin (1½-3mm) slices. A mandolin will do the job most uniformly, or use a sharp knife and carefully cut slices as thinly as possible.
- As you are slicing the potato, put the slices immediately into a bowl of cold water.
- Wash and rinse the slices until the water stays clear. Then dry the slices in a clean tea towel, or spin them in a salad spinner.
- Arrange the slices in a single layer on a dinner plate lined with paper towel, making sure the slices do not touch each other.
- Sprinkle the slices with a little salt, or any other seasoning of choice.
- Brushing the slices with a little olive oil before seasoning is not necessary for a crispy result, but will give a richer taste.
- Microwave the slices at 100% power for 3 minutes, then flip them over and microwave at 40% for another three minutes. As the crisps are starting to crisp and brown, remove them immediately.
- Continue cooking the remaining crisps at 40% power in 1 minute intervals until crispy and golden.
- Transfer cooked crisps to a bowl and repeat the steps above for the remaining batches.

# Recipes (Cont.)

## Scrambled eggs

### Ingredients (serves 2)

4 eggs

4 tbsp milk

Salt and freshly ground pepper

Fresh chives, chopped

25g butter or dairy spread

### Method

- Whisk the eggs with the milk and seasoning. Add the chives.
- Melt the butter in a microwave safe bowl and spread to cover the base and sides of the bowl.
- Add the egg mixture to the greased bowl and cook with 100% microwave power for 2 minutes, stirring every 30 seconds.

This page has been left blank intentionally.



## 20L Microwave Oven

# Repair and Refurbished Goods or Parts Notice

Unfortunately, from time to time, faulty products are manufactured which need to be returned to the supplier for repair.

Please be aware that if your product is capable of retaining user-generated data (such as files stored on a computer hard drive, telephone numbers stored on a mobile telephone, songs stored on a portable media player, games saved on a games console or files stored on a USB memory stick) during the process of repair, some or all of your stored data may be lost. **We recommend you save this data elsewhere prior to sending the product for repair.**

You should also be aware that rather than repairing goods, we may replace them with refurbished goods of the same type or use refurbished parts in the repair process.

**Please be assured though, refurbished parts or replacements are only used where they meet ALDI's stringent quality specifications.**

If at any time you feel your repair is being handled unsatisfactorily, you may escalate your complaint. Please telephone us on 1300 886 649 or write to us at:

Tempo (Aust) Pty Ltd ABN 70 106 100 252  
PO BOX 6056 Frenchs Forest, Sydney, Australia NSW 2086  
**Tempo Help Desk: 1300 886 649 (Aust)**  
(Operating Hours: Mon-Fri 08:30AM to 06:00PM EST)  
Email: [info@tempo.org](mailto:info@tempo.org)





## Warranty returns

Should you for any reason need to return this product for a warranty claim, make sure to include all accessories with the product.

## Product does not work?

If you encounter problems with this product, or if it fails to perform to your expectations, make sure to contact our After Sales Support Centre on 1300 886 649 before returning it to the store for a refund.

For an electronic copy of this manual, go to [www.stirlingappliances.com.au](http://www.stirlingappliances.com.au) and download a copy.

### Instruction Manual Revision Index

| Version No | Issue Date       | Description      |
|------------|------------------|------------------|
| V1.0       | 09 December 2016 | Original release |
| V1.1       | 30 December 2016 | Minor revisions  |